

(No Model.)

3 Sheets—Sheet 1.

G. G. PRENTICE.
DOUBLE TURRETED CHUCKING LATHE.

No. 589,138.

Patented Aug. 31, 1897.

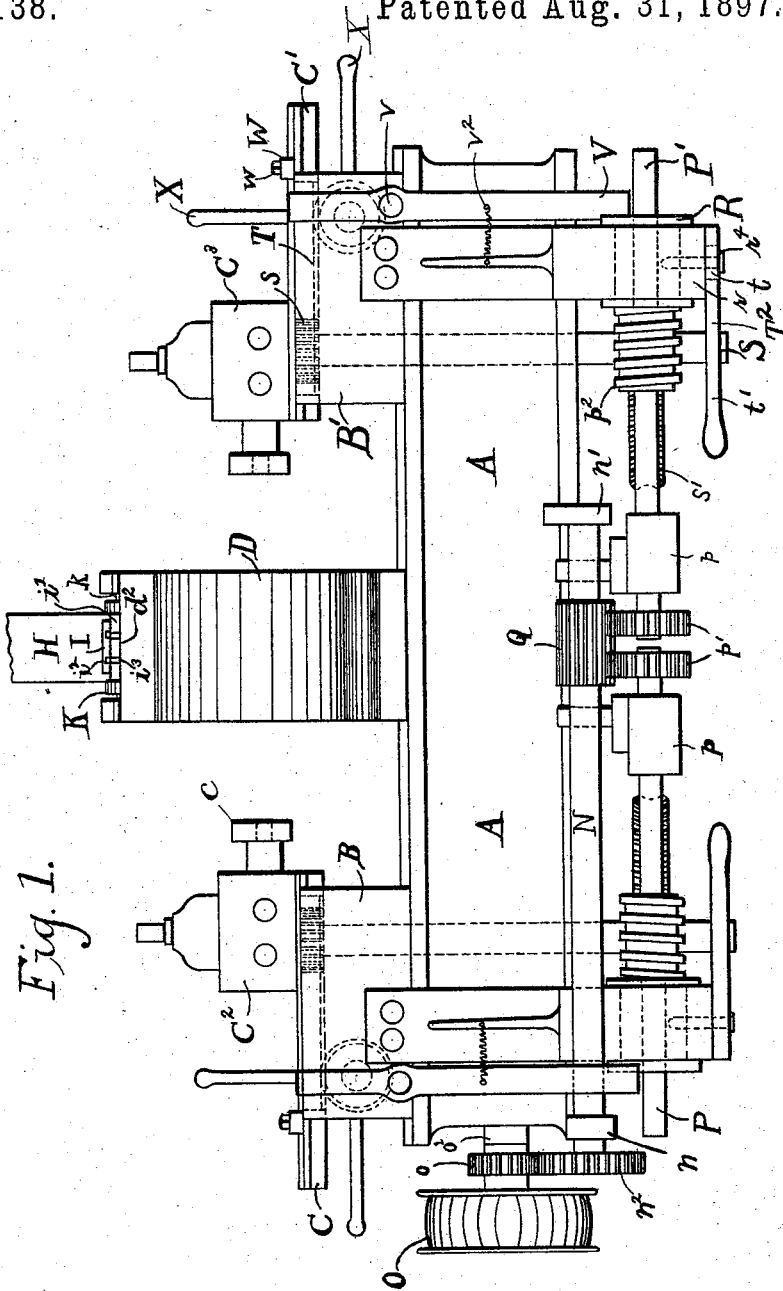

Fig. 1.

WITNESSES:

W. Philip Tamworth.
Samuel J. J.

INVENTOR

George G. Prentice
BY *Robinson & Fisher*
his ATTORNEYS

G. G. PRENTICE.
DOUBLE TURRETED CHUCKING LATHE.

No. 589,138.

Patented Aug. 31, 1897.

Fig. 2.

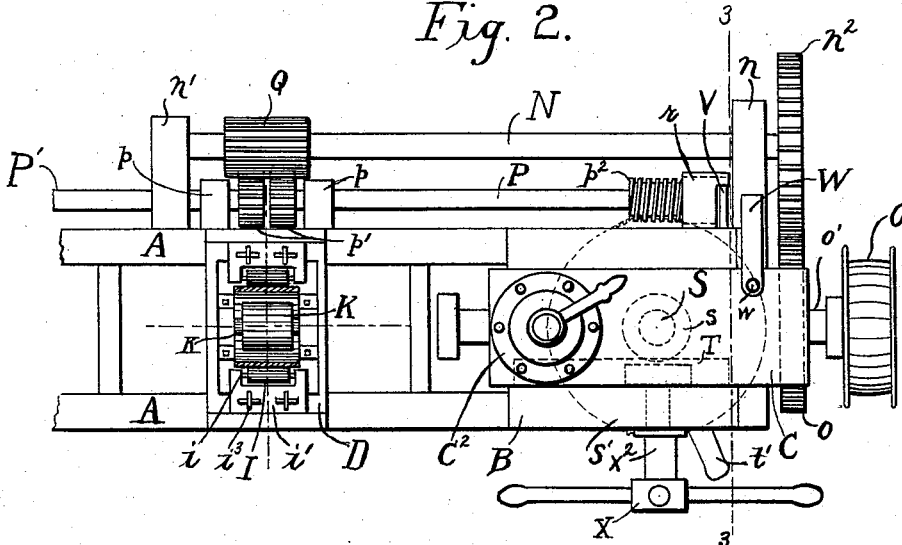

Fig. 3.

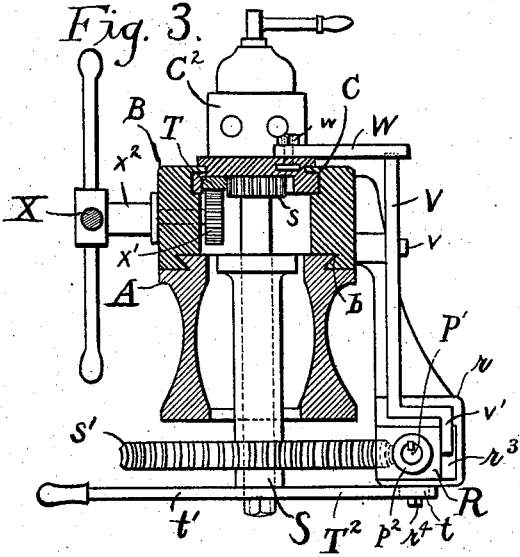
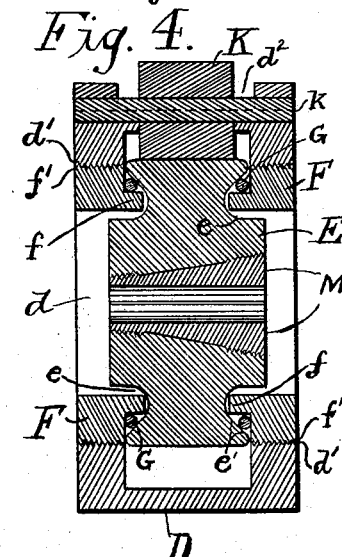

Fig. 4.



WITNESSES:

G. Philip Tammworth.
Samuel Dyck Jr.

INVENTOR

George G. Prentice
BY *Robinson Fisher*
his ATTORNEYS.

G. G. PRENTICE.
DOUBLE TURRETED CHUCKING LATHE.

No. 589,138.

Patented Aug. 31, 1897.

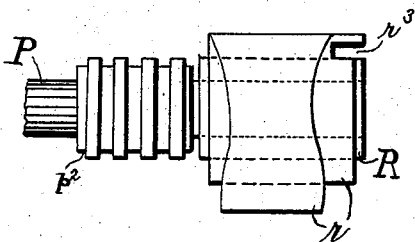
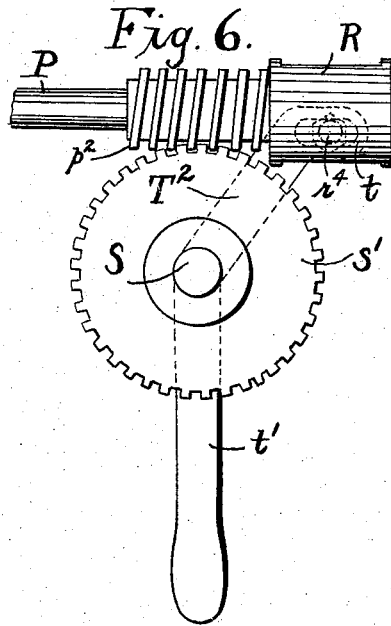
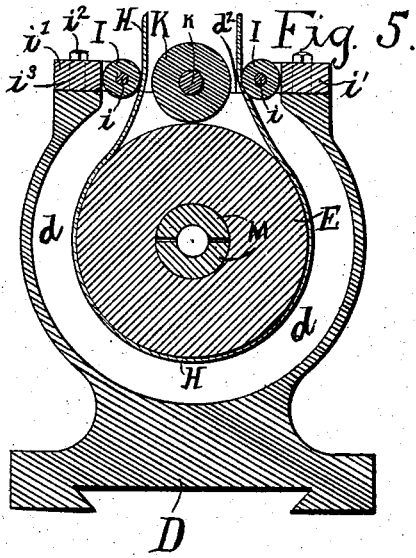

Fig. 8.

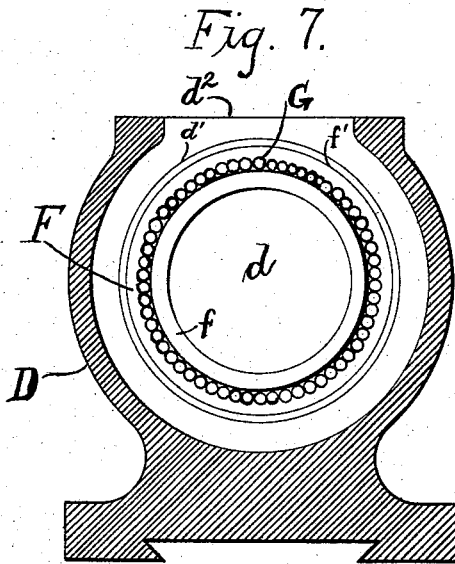

Fig. 7.

WITNESSES:

P. Philip Farnsworth.
Samuel J. ...

INVENTOR

George G. Prentice
BY *Robinson & Fisher*
his ATTORNEYS.

UNITED STATES PATENT OFFICE.

GEORGE G. PRENTICE, OF NEW YORK, N. Y.

DOUBLE-TURRETED CHUCKING-LATHE.

SPECIFICATION forming part of Letters Patent No. 589,138, dated August 31, 1897.

Application filed July 22, 1895. Serial No. 556,820. (No model.)

To all whom it may concern.

Be it known that I, GEORGE G. PRENTICE, a citizen of the United States, and a resident of the city, county, and State of New York, have invented a new and useful Double-Turreted Chucking-Lathe, fully set forth and described in the following specification, taken in connection with the drawings which form part thereof, and in which the same letters of reference represent like parts in all figures.

Figure 1 is a rear elevation of a lathe embodying my invention. Fig. 2 is a plan view of the central part and one end of the lathe. Fig. 3 is a transverse section on lines 3 3 of Fig. 2. Fig. 4 is a longitudinal central section through the chuck. Fig. 5 is a transverse section through the same. Fig. 6 is a detail view of the journal-box, operating-lever, worm-wheel, &c. Fig. 7 is a transverse section of the chuck with the revolving head omitted. Fig. 8 is a detail view of the journal-box and supporting-bracket.

This invention relates to lathes in which the stock is held by a revolving socket and the tools, which are mounted on a turret or tool-holder, are brought into action upon the stock. This class of lathes is commonly known as a "chucking-lathe;" and the object of this invention is the construction of a lathe having two turrets or tool-holders bringing tools simultaneously into action upon both ends of the stock, which is held between the two turrets in a chuck of novel form.

The peculiar features of this lathe consist principally in the chuck which holds and revolves the stock, exposing both ends thereof to the operation of the tools, two turrets which are synchronously moved toward and from the stock, and mechanism for operating the same, as more fully described and claimed hereinafter.

In the drawings, A represents the bed of the lathe, upon which are mounted at either end the two turret-beds B and B', dovetailed to the lathe-bed A, as shown at *b* in Fig. 3, so that they may be adjusted for various lengths of stock to be operated upon. Mounted on the turret-beds B and B' are the turret-slides C and C' and turrets or tool-holders C² and C³, having sockets *c* therein for tools. (Not shown.) The turret-slides C and C', as shown in Fig. 3,

are likewise dovetailed in the turret-beds B and B', respectively, to slide longitudinally therein. Mounted about the central point of the top of the lathe-bed A the chuck D is dovetailed therein to permit of longitudinal adjustment where the character of the work requires unequal action on the two ends thereof. The chuck-body D consists of a portion of cast metal, practically circular in cross-section, having a hollow interior *d*, in which a hollow head E is adapted to revolve, being held in place by channel-plates F. The circular channel-plates F, screw-threaded on their outer edges *f'* to engage with internal threading *d'* in the interior *d* of the chuck-body D, have the internally-projecting flanges *f*, forming right angles with the inner sides of the plates F. The head E has on both ends circular grooves *e*, angular in section, for the reception of the flanges *f* of the channel-plates F when the plates are screwed into the chuck-body. Within the angular channels formed by the channel-plates F and the beveled sides *e'* of the grooves *e* are steel balls G, the whole forming ball-bearing in said chuck, upon which the head E may revolve.

Through the rectangular opening *d*² in the top of the chuck-body D from any suitable counter-shaft extends a belt H around the head E. Across the opening *d*² extends lengthwise the axle *k*, upon which revolves the pulley K, pressing against the upper surface of the revolving head E to counteract the tendency of the belt H to draw the head upward. To further convert the lifting power of the belt into a circular force, idler-pulleys I, mounted on short shafts *i*, secured to adjustable plates *i'*, extend laterally into the opening *d*² and bear against the belt H. The plates *i'* being secured to the top of the chuck-body D by screw and nut *i*², extending through the slot *i*³ in the plate, the idler-pulleys I may be adjusted to bear more or less upon the belt H.

The socket or jaws M, in the form of a truncated cone, split longitudinally to hold various sizes of stock, is threaded a short distance from its two ends to correspond with threading on the interior of the hollow revolving head E. When the stock is placed within the socket M, the socket is inserted in the inte-

rior of the head E and a few turns of the socket will secure it therein. The revolving motion of the head is thereby transmitted to the stock.

5 The construction of the parts of the chuck may vary somewhat without departing from the spirit of the invention, as the revolving head may be driven by gearing mechanism, chain, or cable, as well as belting.

10 The method of synchronously operating the two turrets is as follows: A power-shaft N extends longitudinally parallel to and in the rear of the lathe-bed, to which it is connected by brackets n and n' . Gear n^2 at one end of the shaft N meshes with gear o , rigidly connected to the pulley O, mounted on a short arbor o' in the end of the lathe-bed. Pulley O is connected to suitable counter-shafting and by means of gears o and n^2 transmits

20 power to the shaft N.
Two short shafts P and P', parallel to the shaft N, extend from the center of the lathe-bed toward either end. The inner ends of the shafts P and P' bear in brackets p , which are hinged to the lathe-bed to swing in a horizontal plane, and gears p' mesh with the pinion Q, rigidly secured to the shaft N, and transmit motion therefrom to the two shafts P and P'. The mechanism for driving both turrets being similar, the description of one (the right hand) will suffice for both. The outer end of the shaft P', having near its end a worm p^2 , is journaled in a box R. A bracket r , rigidly secured to the turret-bed, surrounds the box R and allows it a limited movement transverse to the length of the shaft P. Securely held in the lathe-bed beneath the turret-bed B is a vertical shaft S, having at the top a pinion s , meshing with a rack T on the under side of the turret. At the lower end of the shaft S a worm-wheel s' , rigidly mounted thereon, is adapted to mesh with the worm p^2 when the journal-box R is in a position in the bracket r adjacent to the lathe-bed. Power from the pulley O is communicated by the above system of shafts and gears to the turret C as long as the journal-box R is adjacent to the lathe-bed, but upon the movement of the box R in the bracket r away from the lathe-bed (separating the worm p^2 and wheel s') the connection is broken and the turret is free to move independent of pulley O.

A vertical lever V is pivoted at v to the turret-bed B to swing in a vertical plane parallel to the rear side of the lathe-bed. The lower end of the lever V has a hook v' , adapted to enter a slot r^3 in the side of the bracket r , and when in said slot to rest behind the journal-box R and hold it adjacent to the lathe-bed and the worm p^2 in mesh with the worm-wheel s' . The lever V is held normally with its end v' in the slot r^3 by means of a spring v^2 , connecting the lever V and bracket r . A tripper W, secured to the turret-slide C by the screw-nut w , extends laterally therefrom and in the forward movement of the turret, (to bring the tool in contact with the stock,) 65

when the operation of the tool is completed, engages with the upper end of the lever V and turns it about its center v , withdrawing 70 the hooked end v' , against the tension of the spring v^2 , from the slot r^3 in the bracket r . The box R is thereupon pressed away from the lathe-bed by a spring (not shown, and which may be placed at any convenient point) 75 and the worm p^2 thrown out of mesh with the worm-wheel s' .

The turret, which is of ordinary construction, may be drawn back by the pilot-wheel X and pinion x on the horizontal shaft x^2 , 80 connected thereto, engaging with teeth on the under side of the rack T. To again connect the turret with the power-shaft, a short vertical arbor r^4 extends beneath the box R, to which it is secured. A lever T², pivoted 85 beneath the worm-wheel s' to the end of the shaft S to swing in a horizontal plane, extends to the front of the lathe for an operating-handle t' and to the rear beneath the box R. The arbor r^4 engaging in a slot t in the end of the lever T², upon the movement of the handle t' the arbor r^4 and the box R are drawn toward the lathe-bed and when brought adjacent thereto and the worm p^2 and worm-wheel s' are again in mesh the end 95 v' of the vertical lever V will again enter the slot r^3 under the tension of spring v^2 .

It is obvious that the worm p^2 will vary on the two shafts P and P' in that the one will be right and the other left handed. The construction may vary somewhat without departing from the spirit of this invention; but 100

What I claim is—

1. In a lathe the combination with a centrally-disposed chuck, having a hollow interior; removable channel-plates at both ends of said chuck secured to the same; and a head mounted to revolve on said channel-plates, and adapted to hold stock so that both ends thereof may be operated upon simultaneously, 105 substantially as described.

2. In a lathe, the combination with a centrally-disposed chuck; of channel-plates on both ends thereof, said plates having inwardly-extending circular flanges; a head with circular grooves on both ends to fit over said flanges of said plates, and adapted to revolve thereon, substantially as described. 115

3. In a lathe, the combination with a centrally-disposed chuck, having a hollow interior; channel-plates at both ends of said chuck secured to the same; a head mounted to revolve on said channel-plates, and internally adapted to receive jaws to hold stock so that both ends may be operated upon simultaneously; and mechanism for revolving said head, substantially as described. 120 125

4. In a lathe the combination with a centrally-disposed chuck having a hollow interior; removable channel-plates at both ends 130 of said chuck, having inwardly-projecting flanges; a hollow head mounted to revolve in ball-bearings on the flanges of said channel-plates; and jaws adapted to be secured within

said head to revolve therewith and hold stock against longitudinal and turning movement therein, substantially as described.

5. In a lathe, the combination with a centrally-disposed chuck; of tool-holders on opposite sides thereof having separate operating mechanisms; a driving-shaft; two intermediate shafts pivoted at their inner ends to swing in a horizontal plane, said inner ends receiving motion from said driving-shaft, the outer ends being adapted to be connected and disconnected with said operating mechanisms, substantially as described.

6. In a lathe, the combination with a centrally-disposed chuck; of tool-holders on opposite sides thereof, having separate operating mechanisms; a driving-shaft; two intermediate shafts pivoted at their inner ends to swing in a horizontal plane, said inner ends receiving motion from said driving-shaft, the outer ends bearing in journal-boxes; brackets in which said journal-boxes are capable of a limited transverse sliding movement to connect and disconnect said shafts with said operating mechanisms, substantially as described.

7. In a lathe, the combination with the lathe-bed; of a tool-holder; of a driving-shaft, pivoted at one end to the lathe-bed, the other end thereof bearing in a journal-box; a bracket secured to the lathe-bed in which said journal-box is capable of a limited horizontal sliding movement transverse to the length of said driving-shaft; and operating mechanism for said tool-holder connected and disconnected with said driving-shaft upon the movement of said journal-box, substantially as described.

8. In a lathe, the combination with a tool-holder, of a driving-shaft hinged at one end to swing in a horizontal plane the other end thereof bearing in a journal-box capable of a

limited transverse sliding movement in a supporting-bracket; a lever pivoted so that one end thereof may engage in said supporting-bracket and lock said journal-box against movement; and operating mechanism for said tool-holder connected to said driving-shaft when said journal-box is locked by said lever, substantially as described.

9. In a lathe, the combination with a tool-holder, of operating mechanism for the same; a driving-shaft pivoted at one end, the other end thereof bearing in a journal-box capable of a limited transverse horizontal sliding movement in its supporting-bracket, connecting and disconnecting said driving-wheel with said operating mechanism; a lever pivoted so that one end may engage in said supporting-bracket and lock said journal-box to connect said driving-shaft and operating mechanism; and a tripper on said tool-holder for disengaging said lever from said supporting-bracket to unlock said journal-box, substantially as described.

10. In a lathe, the combination with a tool-holder; of operating mechanism for the same; a driving-shaft one end of which bears in a journal-box capable of a limited horizontal sliding movement in its supporting-bracket transverse to the length of said driving-shaft to connect and disconnect said driving-shaft and operating mechanism; and a lever pivoted to swing in a horizontal plane, one end of which is connected to said journal-box for giving the same its transverse motion; substantially as described.

In witness whereof I have hereunto set my hand this 19th day of July, 1895.

GEORGE G. PRENTICE.

Witnesses:

GEORGE D. LOCKWOOD,

GEORGE W. ROBINSON.